

**NPT AU Line  
Refrigerated Counter 3 Doors  
(R290)**

ITEM # \_\_\_\_\_

MODEL # \_\_\_\_\_

NAME # \_\_\_\_\_

SIS # \_\_\_\_\_

AIA # \_\_\_\_\_



111163 (ZJ3HBAAA)

3-door refrigerated counter, -2+10°C (R290), AISI 304

**Short Form Specification**

Item No. \_\_\_\_\_

Internal and external doors, front and side panels in 304 AISI stainless steel. N.3 doors. Built-in refrigeration unit. Ventilated. Refrigerant R290. High-density expanded polyurethane foam, 90 mm in thickness, with cyclopentane injection. Digital control panel. Completely automatic defrosting and automatic evaporation of defrost water obtained by hot gas. Temperature range: -2+10°C. CFC and HCFC free. Feet in 304 AISI stainless steel, adjustable in height.

APPROVAL: \_\_\_\_\_

**Main Features**

- Tropicalized unit (43°C ambient temperature).
- Adjustable temperature range from -2 °C to +10 °C to suit meat, fish and dairy storage requirements.
- Anti-tilt runners accept GN 1/1 containers.
- Combination of doors and drawers to suit varying needs, with the possibility to change the configuration on site.
- Digital control panel.
- Forced air circulation for rapid cooling and an even temperature distribution.
- Refrigerated compartment designed to accept GN 1/1 containers.
- Self closing stainless steel doors (< 90°).
- Removable triple-chamber balloon magnetic gasket to improve insulation and reduce energy consumption and ease of cleaning.
- Fully compliant HACCP digital control: when temperature exceeds critical limits, acoustic and visual alarms are activated. Up to two months of event are kept in memory.
- Prearranged to fit RS485 port to facilitate connection to a remote computer and integrated HACCP systems.
- 0mm clearance installation space: tower configuration cooling unit guarantee performance with frontal ventilation only; this unique solution allows installation against the wall or side by side with other appliances, even on the cooling unit side to maximize the use of kitchen space.
- Hot gas automatic evaporation of defrost water.
- Preservation performances and temperature uniformity within the cell guaranteed at 5-HEAVY DUTY (40°C) working conditions according to EN16825:2016 test protocol.
- Fitted with 90 mm thickness of cyclopentane insulation for best insulating performance (thermal conductivity: 0,020 W/m\*K) and lowest environmental impact (GWP=3).
- Combination of doors and drawers to suit any configuration needed, with the possibility to change the configuration on site. Right cooling unit available on request.
- Frontal and easy access to all components in the cooling unit.
- Mounted on stainless steel feet to give 150 mm (-5/+50 mm) clearance for ease of cleaning the floor.
- Certified safety CE requirements.
- Small footprint to fit even in limited environments.
- CFC and HCFC free, highly ecological refrigerant type: R290 (ecological gas in foam: cyclopentane). Hydrocarbon refrigerant gas R290 for the lowest environmental impact (GWP=3), to reduce green house and ozone depletion effects.
- Kit 1/3 drawers available as accessory.
- Connectivity ready for real time access to connected appliances from remote and data monitoring (requires optional accessory).
- Digital control panel allowing the easy and precise setting and control of the internal temperature.
- Operating temperature can be adjusted from -2 to +10 °C to suit different food storage requirements.
- This appliance is intended for use in ambient temperatures up to 40°C.
- Complies with main international certification bodies and is CE marked.
- Kit 1/2 drawers available as accessory.

- The door self-closes when opened less than at a 90° angle and is equipped with a door seal to guarantee perfect closure.
- Completely automatic defrosting and automatic evaporation of defrost water by hot gas.
- Forced air cooling system guaranteeing great uniformity of the temperature in the counter and excellent conservation of the food quality.
- High standards of hygiene and ease of cleaning are guaranteed by the rounded internal corners of the cabinet and easily removable runners and grids.

- Kit 4 wheels, H=100 mm (2 with brakes) for refrigerated counters PNC 881191
- Kit 4 wheels, H=150 mm (2 with brakes) for 2&3 compartment refrigerated counters PNC 881193
- Lock for refrigerated counters with three compartments - h650mm PNC 881246

## Construction

- Access to all components from the front.
- Developed and produced in ISO 9001 and ISO 14001 certified factory.
- Fault code display.
- Interior base with rounded corners, pressed from a single sheet.
- Internal and external doors, front, back and side panels in AISI 304 Stainless steel.
- Mounted on Stainless steel adjustable legs to give 150 mm clearance for ease of cleaning.
- Rounded internal corners for ease of cleaning.
- Pre-arranged for drain-pipe.
- Built-in refrigeration unit.
- Ease of cleaning and high hygiene standards thanks to the rounded internal corners, the easily removable runners, grids and air conveyors.
- Internal structure with 15 charging positions (3 cm pitch) available to host GN 1/1 grids, ensuring higher net capacity and a greater storage space.
- Extractable cooling unit to facilitate maintenance.
- IP21 protection index.
- Built-in compressor to suit operating conditions.
- Legs in 304 AISI stainless steel (150 mm high, adjustable in height), with plastic interior.
- Insulation guaranteed by high density expanded cyclopentane 50 mm in thickness.
- Internal and external doors, front and side panels and 50mm thick removable worktop in 304 AISI stainless steel.
- Back panel in galvanized steel.

## Included Accessories

- 3 of Kit 1/1 grey rilsan grid and 2 side runners for refrigerated counters PNC 881109

## Optional Accessories

- Kit integrated HACCP for digital refrigerators (IR33) PNC 880252
- 1/1GN grey rilsan grid for refrigerated counters PNC 881107
- 2 side runners for 1/1 GN refrigerated counters PNC 881108
- Kit 1/1 grey rilsan grid and 2 side runners for refrigerated counters PNC 881109
- 1/1 GN plastic container, H=65 mm PNC 881110
- 1/1 GN plastic container, H=100 mm PNC 881111
- 1/1 GN plastic container, H=150 mm PNC 881112
- 2x½ drawer kit for refrigerated counters - h650mm PNC 881176
- 3x1/3 drawer kit for refrigerated counters - h650mm (only for refrigerated counters) PNC 881177
- 1/3 and 2/3 bottle drawer kit for refrigerated counters - h650mm (only for refrigerated counters) PNC 881178

**Front**

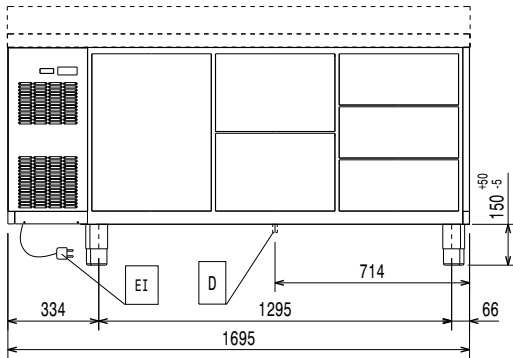

**Side**



EI = Electrical inlet (power)

**Top**

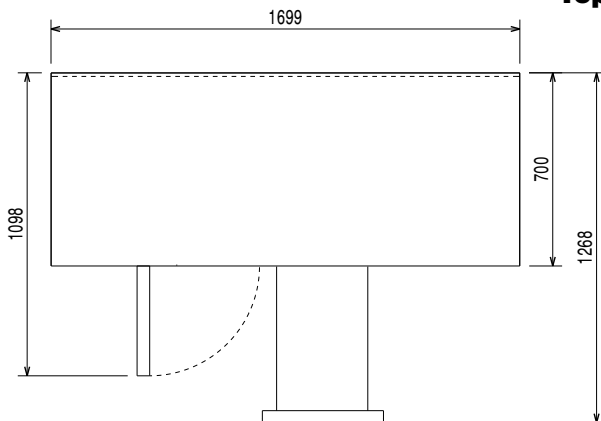

**Electric**

Supply voltage:  
111163 (ZJ3HBAAA) 220-240 V/1 ph/50 Hz  
Electrical power max.: 0.22 kW

**Key Information:**

Gross capacity:  
Net Volume: 245.399993896484 lt  
External dimensions, Width: 1699 mm  
External dimensions, Height: 850 mm  
External dimensions, Depth with Doors Open: 1310 mm  
Internal Dimensions (depth): 560 mm  
Internal Dimensions (height): 510 mm  
Internal Dimensions (width): 1252 mm  
Net weight: 114 kg  
Noise level: 48 dBA  
Built-in Compressor and Refrigeration Unit

**Refrigeration Data**

Control type: Digital  
Compressor power: 1/4 hp  
Refrigerant type: R290  
Refrigeration power: 320 W  
Refrigerant weight: 65 g  
Min/Max internal humidity: 40/85  
Operating temperature min.: -2 °C  
Operating temperature max.: 10 °C  
Operating mode: Ventilated

**Product Information (EU Regulation 2015/1094)**

Energy Class: B  
Yearly and daily energy consumption: 605kWh/year - 2kWh/24h  
Climate class: Heavy Duty (5)  
Energy Efficiency Index (EEI): 25,03

**EU energy labelling from 1st July 2016**

The European energy labelling scheme for professional refrigerators and freezers is based on requirements setting Minimum Energy Performance standards for commercial refrigeration cabinets sold within the EU. These requirements are designed to drive energy efficiency and environmentally friendly approach for professionals. The European energy labelling scheme will apply to all manufacturers and importers who sell and market products within the EU and it is mandatory across Europe. Important: all products which consume energy above the minimum level will not be able to be sold within the EU from 1 July 2016.

SI 2020 No. 1528.

Important: all products which consume energy above the minimum level will not be able to be sold within the EU from 1 July 2016.

