

Convection Oven Electric Convection Oven, 6 GN1/1

ITEM # _____

MODEL # _____

NAME # _____

SIS # _____

AIA # _____



240451 (ZFCE61CSDS)

Convection oven crosswise,
6x1/1GN, electric

240452 (ZFCE61CSCS)

Convection oven crosswise,
6x1/1GN, electric

Short Form Specification

Item No. _____

Convection oven with direct steam. Main structure in stainless steel. Cooking chamber with side lightning and drip tray. Double glass door. Heating via "Incoloy" armoured elements positioned on the convector unit. Electromechanical thermostat; temperature adjustable from 30°C to 300°C. Timer from 0 to 120 minutes with acoustic alarm. 5-level humidity control.

Supplied with n. 1 "cross-wise" tray rack composed by 2 side hangers, 60 mm pitch, for 6x1/1GN grids.

Main Features

- Main switch/Cooking mode selector which can be used to set: ON/OFF, hot air without humidification and hot air with humidification (choice of 5 different humidity levels).
- Rapid cooling of oven cavity.
- Timer to set the cooking time, adjustable up to 120 minutes or for continuous operation with an acoustic alarm to show the cycle has finished. At the end of the set cooking time the heat and the fan are automatically switched off.
- Maximum temperature of 300°C.
- Perfect evenness: guarantees perfect distribution of heat throughout the oven cavity.
- Halogen lighting and "crosswise" pan supports allow clear and unobstructed view of the products being cooked.
- Food temperature probe (available as accessory).
- Drip tray to collect residual cooking juices and fat.
- Drip tray under the door to collect condensed liquid available as accessory.
- Manual valve to adjust the position of steam evacuation flap.
- Capacity: 6 GN 1/1 trays.

Construction

- Robust structure thanks to stainless steel construction.
- Cooking chamber in 430 AISI stainless steel.
- Double thermo-glazed door with open frame construction, for cool outside door panel. Swing hinged easy-release inner glass on door for easy cleaning.
- Ergonomic door handle.
- Integrated drain outlet.
- 1 pair of 60 mm pitch runners is supplied as standard.
- IPx4 water protection.

APPROVAL: _____

Optional Accessories

- | | | |
|---|------------|--------------------------|
| • Pair of AISI 304 stainless steel grids, GN 1/1 | PNC 921101 | <input type="checkbox"/> |
| • Pair of 1/2 GN pan support shelves | PNC 921106 | <input type="checkbox"/> |
| • Water softener with salt for ovens with automatic regeneration of resin | PNC 921305 | <input type="checkbox"/> |
| • Probe for 6-10 1/1 GN ovens | PNC 921702 | <input type="checkbox"/> |
| • 1/1 GN drain pan guide kit | PNC 921713 | <input type="checkbox"/> |
| • Pair of AISI 304 stainless steel grids, GN 1/1 | PNC 922017 | <input type="checkbox"/> |
| • Pair of grids for whole chicken (8 per grid - 1,2kg each), GN 1/1 | PNC 922036 | <input type="checkbox"/> |
| • AISI 304 stainless steel grid, GN 1/1 | PNC 922062 | <input type="checkbox"/> |
| • Open base for 6 GN 1/1 convection oven | PNC 922101 | <input type="checkbox"/> |
| • Shelf guides for 6 1/1 GN oven base | PNC 922105 | <input type="checkbox"/> |
| • Retractable hose reel water spray unit | PNC 922170 | <input type="checkbox"/> |
| • External side spray unit (needs to be mounted outside and includes support to be mounted on the oven) | PNC 922171 | <input type="checkbox"/> |
| • Fat filter for 6 GN ovens | PNC 922177 | <input type="checkbox"/> |
| • Pair of frying baskets | PNC 922239 | <input type="checkbox"/> |
| • Grid for whole chicken (8 per grid - 1,2kg each), GN 1/1 | PNC 922266 | <input type="checkbox"/> |
| • Kit universal skewer rack and 6 short skewers for Lengthwise GN 2/1 and Crosswise ovens | PNC 922325 | <input type="checkbox"/> |
| • Universal skewer rack | PNC 922326 | <input type="checkbox"/> |
| • 6 short skewers | PNC 922328 | <input type="checkbox"/> |
| • Smoker for lengthwise and crosswise oven | PNC 922338 | <input type="checkbox"/> |
| • Drip tray for convection oven 6 GN | PNC 922430 | <input type="checkbox"/> |
| • Mesh grilling grid, GN 1/1 | PNC 922713 | <input type="checkbox"/> |
| • Non-stick universal pan, GN 1/1, H=20mm | PNC 925000 | <input type="checkbox"/> |
| • Non-stick universal pan, GN 1/1, H=40mm | PNC 925001 | <input type="checkbox"/> |
| • Non-stick universal pan, GN 1/1, H=60mm | PNC 925002 | <input type="checkbox"/> |
| • Double-face griddle, one side ribbed and one side smooth, GN 1/1 | PNC 925003 | <input type="checkbox"/> |
| • Aluminum grill, GN 1/1 | PNC 925004 | <input type="checkbox"/> |
| • Frying pan for 8 eggs, pancakes, hamburgers, GN 1/1 | PNC 925005 | <input type="checkbox"/> |

Front

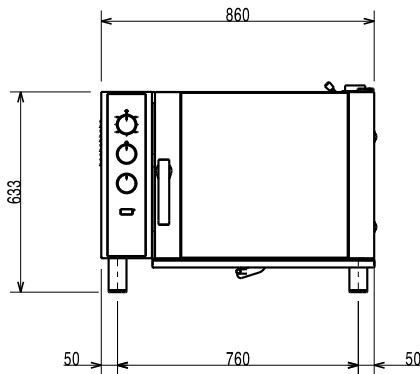

Side

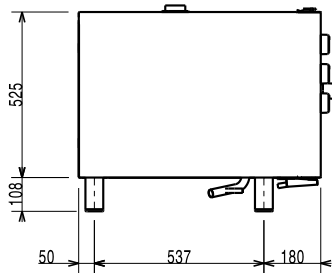

- CWI1** = Cold Water inlet 1 (cleaning)
- CWI2** = Cold Water Inlet 2 (steam generator)
- D** = Drain
- EI** = Electrical inlet (power)

Top

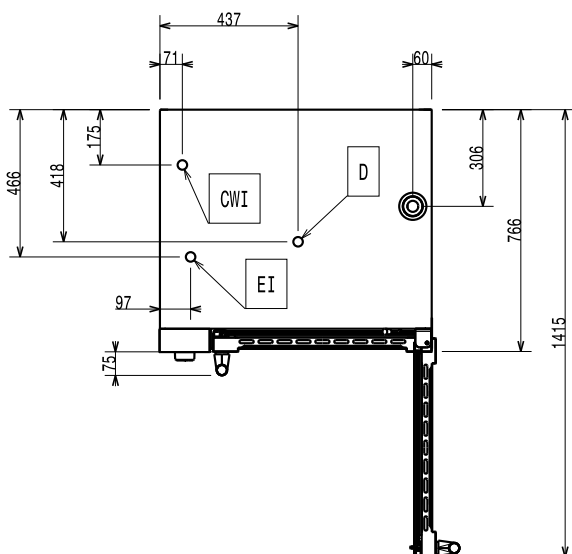

Electric

Supply voltage:

240451 (ZFCE61CSDS)	380-400 V/3N ph/50 Hz
240452 (ZFCE61CSCS)	230 V/3 ph/50 Hz

Electrical power max.:

7.7 kW

Capacity:

Trays type:	6 - 1/1 Gastronorm
Shelf capacity:	6

Key Information:

External dimensions, Width:	860 mm
External dimensions, Depth:	767 mm
External dimensions, Height:	633 mm
Net weight:	79.5 kg
Functional level:	Basic
Runners pitch:	60 mm
Cooking cycles - air-convection:	300 °C
Heating-up time (hot air cycle):	215°C / 300s.